



Cryptographic algorithms

Prof. Bart Preneel
COSIC
Bart.Preneel(at)esatDOTkuleuven.be
http://homes.esat.kuleuven.be/~preneel
February 2015



© Bart Preneel. All rights reserved



Outline

- 1. Cryptology: concepts and algorithms
 - symmetric algorithms for confidentiality
 - symmetric algorithms for data authentication
 - public-key cryptology
- 2. Cryptology: protocols
 - identification/entity authentication
 - key establishment
- 3. Public-Key Infrastructure fundamentals



Outline (2)

- 4. Network security protocols
 - web (SSL/TLS) and Ipsec
- 5. Post-Snowden cryptography
- 6. Cryptography best practices

Definitions

	data	entities
<div style="border: 1px solid black; padding: 2px; width: fit-content;">Confidentiality</div> <div style="border: 1px solid black; padding: 2px; width: fit-content;">Integrity</div> <div style="border: 1px solid black; padding: 2px; width: fit-content;">Availability</div>	<div style="border: 1px solid black; padding: 2px; width: fit-content;">confidentiality</div> <div style="border: 1px solid black; padding: 2px; width: fit-content;">authentication</div>	<div style="border: 1px solid black; padding: 2px; width: fit-content; background-color: #ffffcc;">encryption</div> <div style="border: 1px solid black; padding: 2px; width: fit-content; background-color: #ccffcc;">data authentication</div> <div style="border: 1px solid black; padding: 2px; width: fit-content; background-color: #ccccff;">identification</div> <div style="border: 1px solid black; padding: 2px; width: fit-content; background-color: #ffccff;">Authorisation</div> <div style="border: 1px solid black; padding: 2px; width: fit-content; background-color: #ffccff;">Non-repudiation of origin, receipt</div> <div style="border: 1px solid black; padding: 2px; width: fit-content; background-color: #ffccff;">Contract signing</div> <div style="border: 1px solid black; padding: 2px; width: fit-content; background-color: #ffccff;">Notarisation and Timestamping</div>

Don't use the word authentication without defining it

4

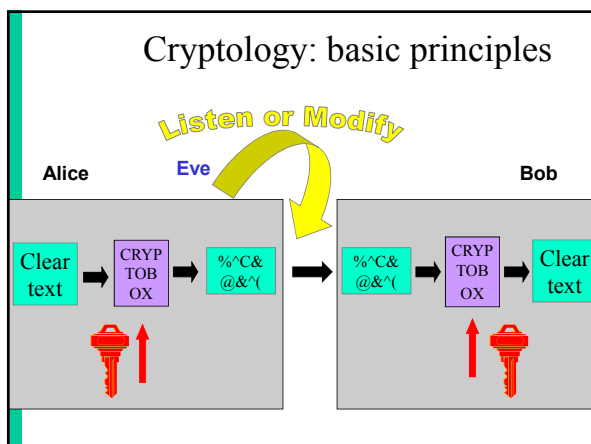

Symmetric cryptology: confidentiality

- old cipher systems:
 - transposition, substitution, rotor machines
- the opponent and her power
- the Vernam scheme
- DES and triple-DES
- AES
- RC4

Old cipher systems (pre 1900)

- Caesar cipher: shift letters over k positions in the alphabet (k is the secret key)

THIS IS THE CAESAR CIPHER
WKL V LV WKH FDHVDU FLSKHU



- Julius Caesar never changed his key ($k=3$).

7

Cryptanalysis example:

TIPGK RERCP JZJZJ WLE	GVCTX EREPC WMWWM JYR
UJQHL SFSDQ KAKAK XMF	HWDUY FFSQD XNXXN KZS
VKRIM TGTER LBLBL YNG	IXEVZ GTGRE YOYOY LAT
WLSJN UHUF S MCMCM ZOH	JYFWA HUHSF ZPZPZ MBU
XDTKO VOVGT NDNDN API	KZGXB IVITG AQAQA NCV
YNULP WKWHU OEOEO BQJ	LAHYC JWJUH BRBRB ODW
ZOVMQ KXKIV PFPFP CRK	MBIZD KXKVI CSCSC PEX
APWNR YLYJW QGQGO DSL	NCJAE LYLWJ DTDTD QFY
BQXOS ZMXXK RHRHR ETM	ODKBF MZMXX EUEUE RGZ
<u>CRYPT ANALY SISIS FUN</u>	PELCG NANYL FVVFV SHA
DSZQU BOBMZ TJTJT GVO	QFMDH OBOZM GWGWG TIB
ETARV CPCNA UKUKU HWP	RGNEI PCPAN HXHXH UJC
FUBSW DQDOB VLVLV IXQ	SHOFJ QDQBO IYIYI VKD

Plaintext? $k = 17$

8

Old cipher systems (pre 1900) (2)

- Substitutions
 - ABCDEFGHIJKLMNOPQRSTUVWXYZ ! Easy to break using statistical techniques
 - MZLNJSOAXFQGYKHLUCTDVWBIPER
- Transpositions

TRANS	ORI S
POSIT	NOTIT
IONS	OSANP

9

Security

- there are $n!$ different substitutions on an alphabet with n letters
- there are $n!$ different transpositions of n letters
- $n=26$: $n! = 403291461126605635584000000 = 4 \cdot 10^{26}$ keys
- trying all possibilities at 1 nanosecond per key requires....

$$4 \cdot 10^{26} / (10^9 \cdot 10^5 \cdot 4 \cdot 10^2) = 10^{10} \text{ years}$$

keys per second	seconds per day	days per year
-----------------	-----------------	---------------

10

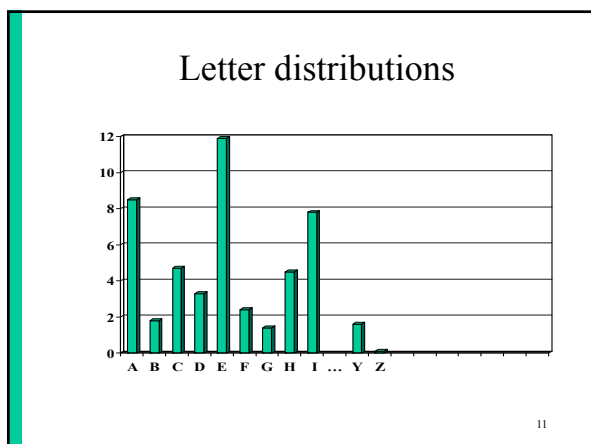

Assumptions on Eve (the opponent)

- A scheme is broken if Eve can deduce the key or obtain additional plaintext
- Eve can always try all keys till “meaningful” plaintext appears: a brute force attack
 - solution: large key space
- Eve will try to find shortcut attacks (faster than brute force)
 - history shows that designers are too optimistic about the security of their cryptosystems

12

Assumptions on Eve (the opponent)

- Cryptology = cryptography + cryptanalysis
- Eve knows the algorithm, except for the key (Kerckhoffs's principle)
- increasing capability of Eve:
 - knows some information about the plaintext (e.g., in English)
 - knows part of the plaintext
 - can choose (part of) the plaintext and look at the ciphertext
 - can choose (part of) the ciphertext and look at the plaintext



13

New assumptions on Eve

- Eve may have access to **side channels**
 - timing attacks
 - simple power analysis
 - differential power analysis
 - acoustic attacks
 - electromagnetic interference
- Eve may launch **(semi-)invasive attacks**
 - differential fault analysis
 - probing of memory or bus

14

Side channel analysis

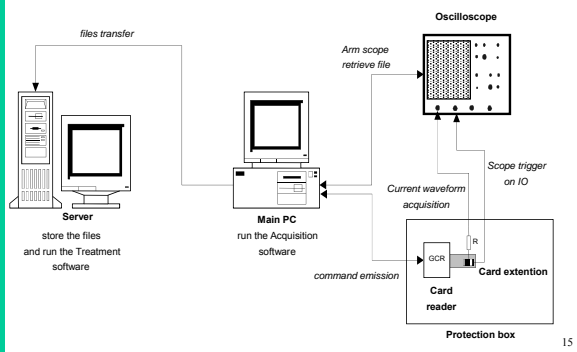

15

Side channel analysis: EMA

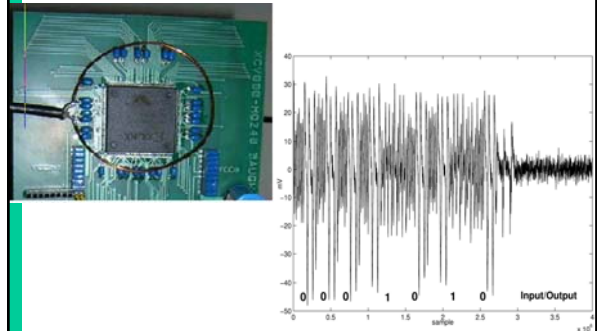

16

Cryptology + side channels

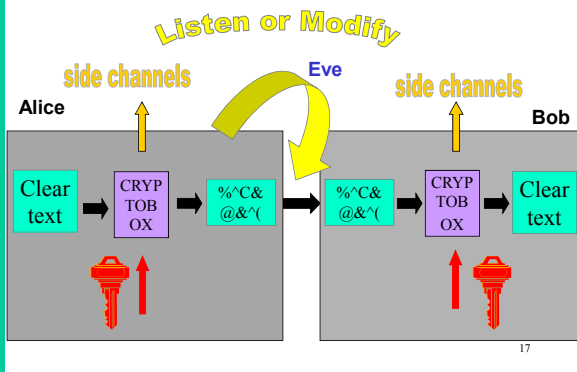

17

The Rotor machines (WW II)

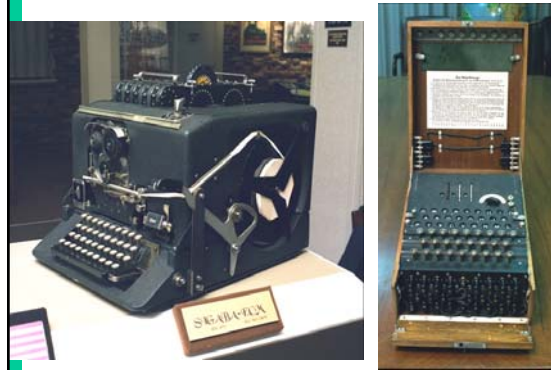

18

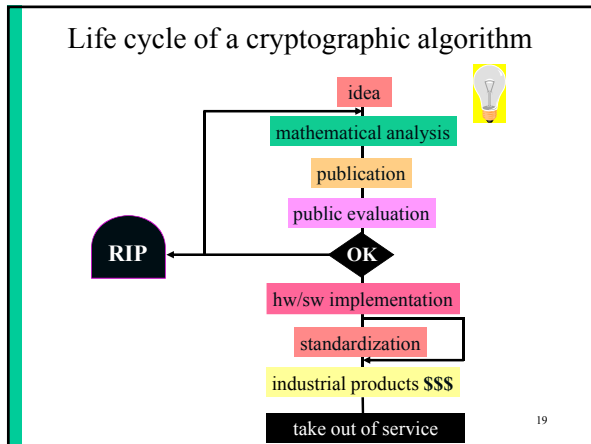

Vernam scheme (1917)
Maugorgne: one time pad (1917+x)

Shannon (1948)

F. Miller (1882)

key is random string, as long as the plaintext
information theoretic proof of security

Encryption: $P = 10010 \oplus K = 01011 \rightarrow C = 11001$

Decryption: $C = 11001 \oplus K = 01011 \rightarrow P = 10010$

Vernam scheme

- $0 + 1 = 1$
- $1 + 0 = 1$
- $0 + 0 = 0$
- $1 + 1 = 0$

- identical mathematical symbols can result in different electrical signals

Three approaches in cryptography

- information theoretic** security
 - ciphertext only
 - part of ciphertext only
 - noisy version of ciphertext
- system-based** or practical security
 - also known as “prayer theoretic” security
- complexity theoretic** security:
 - model of computation, definition, proof
 - variant: quantum cryptography

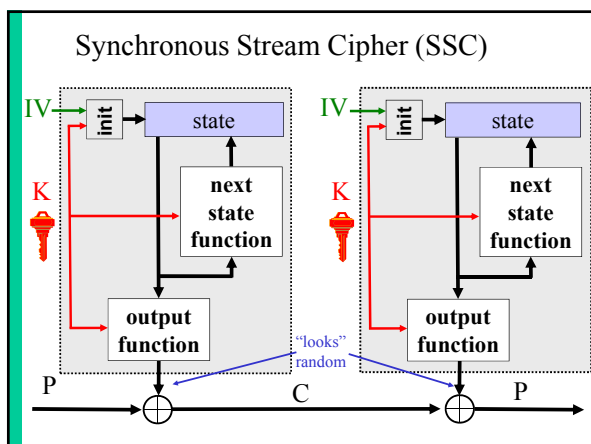

Exhaustive key search

- 2015: 2^{40} instructions is easy, 2^{60} is somewhat hard, 2^{80} is hard, 2^{128} is completely infeasible
 - 1 million machines with 16 cores and a clock speed of 4 GHz can do 2^{26} instructions per second or 2^{80} per year
 - trying 1 key requires typically a few 100 instructions
- Moore’s “law”: speed of computers doubles every 18 months: key lengths need to grow in time
 - but adding 1 key bit doubles the work for the attacker
- Key length recommendations in 2015
 - < 70 bits: insecure
 - 80 bits: one year (but not for NSA)
 - 100 bits: 20 years

Exhaustive key search: multiple targets

- If one wants to recover **1 key out of 2^t keys**, the cost to recover a key is $2^{k-t} < 2^k$
- If one wants to recover **all of 2^t keys** with $t > k/3$ the cost per key can be reduced to $2^{2k/3}$
 - 2^k precomputation to fill a memory of size $2^{2k/3}$
 - on-line cost per key: $2^{2k/3}$ encryptions
 - known as time/memory tradeoff or “rainbow tables”
- So depending on the circumstances, a 128-bit key can become an 85-bit key

25

SSC: Specific properties

- Recipient needs to be synchronized with sender
- No error-propagation
 - excellent for wireless communications
- Key stream independent of data
 - key stream can be precomputed
 - particular model for cryptanalysis: attacker is not able to influence the state

26

SSC: Avoid repeating key stream

- For a fixed key **K** and initial value **IV**, the stream cipher output is a deterministic function of the state.
- A repetition of the state (for a given **K**, **IV**) leads to a repetition of the key stream and plaintext recovery (think of the problem of Vernam encryption with reused key)
 - hence state needs to be large and next state function needs to guarantee a long period
 - **IV** can be used to generate a different key stream for every packet in a packet-oriented communication setting
 - old stream ciphers defined without **IV** are problematic in such a setting

27

Practical stream ciphers

- A5/1 (GSM) (64 or 54)
 - E0 (Bluetooth) (128)
 - RC4 (browser) (40-128)
 - SNOW-3G (3GSM) (128)
 - HC-128 (128)
 - Trivium (80)
 - ChaCha20 (128)
- } **insecure!**

28

A5/1 stream cipher (GSM)

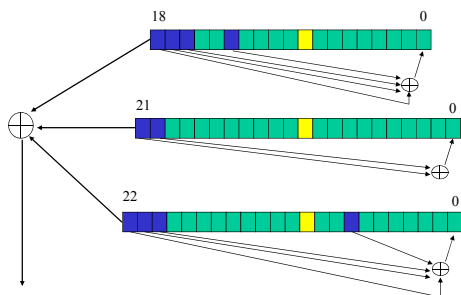

Clock control: registers agreeing with majority are clocked (2 or 3)

29

A5/1 stream cipher (GSM)

- exhaustive key search: 2^{64} (or rather 2^{54})
 - hardware 10KS < 1 minute ciphertext only
- search 2 smallest registers: 2^{45} steps
- [BWS00] 1 minute on a PC
 - 2 seconds of known plaintext
 - 2^{48} precomputation, 146 GB storage
- [BB05]: 10 minutes on a PC,
 - 3-4 minutes of **ciphertext only**
- [Nohl-Paget’09]: rainbow tables
 - seconds with a few frames of **ciphertext only**

30

Bluetooth stream cipher

brute force: 2^{128} steps
[Lu+05] 24 known bits of 2^{24} frames, 2^{38} computations, 2^{33} memory

31

A simple cipher: RC4 (1987)

- designed by Ron Rivest (MIT)
- leaked in 1994
- $S[0..255]$: secret table derived from user key K

```

for i=0 to 255 S[i]:=i
j:=0
for i=0 to 255
    j:=(j + S[i] + K[i]) mod 256
    swap S[i] and S[j]
i:=0, j:=0
    
```

32

A simple cipher: RC4 (1987)

Generate key stream which is added to plaintext

```

i:=i+1
j:=(j + S[i]) mod 256
swap S[i] and S[j]
t:=(S[i] + S[j]) mod 256
output S[t]
    
```

000	001	002		093	094	095		254	255
205	162	013	...	033	92	079	...	099	143

i ↑ j ↑ t ↓

33

RC4: weaknesses

- was often used with 40-bit key
 - US export restrictions until Q4/2000
- best known general shortcut attack: 2^{241} [Maximov-Khovratovich'09]
- weak keys and key setup (shuffle theory)
- large statistical deviations
 - bias of output bytes (sometimes very large)
 - can recover 220 out of 256 bytes of plaintexts after sending the same message 1 billion times (WPA/TLS)
- problem with resynchronization modes (WEP)
- problem with use in TLS

34

Block cipher

- large table: list n-bit ciphertext for each n-bit plaintext
 - if n is large: very secure (codebook)
 - but for an n-bit block: 2^n values
 - impractical if $n \geq 32$
- alternative $n = 64$ or 128
 - simplify the implementation
 - repeat many simple operations

35

Block cipher (2)

- larger data units: 64...128 bits
- memoryless
- repeat simple operation (round) many times

36

Data Encryption Standard (1977)

- encrypts 64 plaintext bits under control of a 56-bit key
- 16 iterations of a relatively simple mapping
- FIPS: US government standard for sensitive but unclassified data
- worldwide de facto standard since early 80ies
- surrounded by controversy

37

Data Encryption Standard (DES)

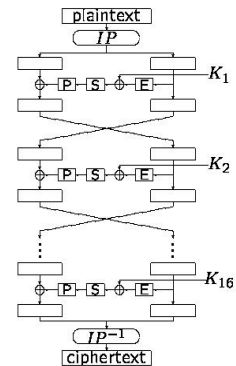

38

The DES round function

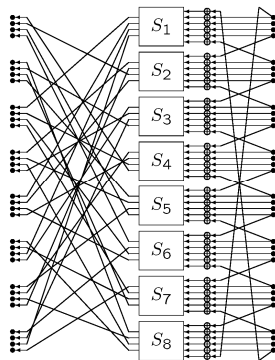

DES S-box 1

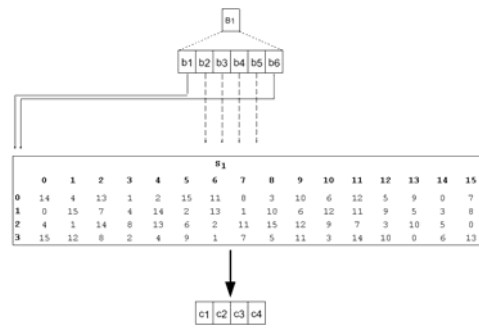

www.gungfu.de



Security of DES (56-bit key)

- PC: trying 1 DES key: 7.5 ns
- Trying all keys on 128 PCs:
1 month: $2^{27} \times 2^{16} \times 2^5 \times 2^7 = 2^{55}$
- M. Wiener's design (1993):
1,000,000 \$ machine: 3 hours
(in 2012: 3 seconds)

EFF Deep Crack (July 1998)
250,000 \$ machine: 50 hours...

41

Federal Register, July 24, 2004

DEPARTMENT OF COMMERCE
National Institute of Standards and
Technology
[Docket No. 040602169- 4169- 01]

Announcing Proposed Withdrawal of
Federal Information Processing
Standard (FIPS) for the Data
Encryption Standard (DES) and
Request for Comments

AGENCY: National Institute of
Standards and Technology (NIST),
Commerce.

ACTION: Notice; request for
comments.

SUMMARY: The Data Encryption Standard (DES), currently specified in Federal Information Processing Standard (FIPS) 46-3, was evaluated pursuant to its scheduled review. At the conclusion of this review, **NIST determined that the strength of the DES algorithm is no longer sufficient to adequately protect Federal government information.** As a result, NIST proposes to withdraw FIPS 46-3, and the associated FIPS 74 and FIPS 81. Future use of DES by Federal agencies is to be permitted only as a component function of the Triple Data Encryption Algorithm (TDEA).

42

3-DES: NIST Spec. Pub. 800-67 (May 2004)

- two-key triple DES: until 2009
- three-key triple DES: until 2030

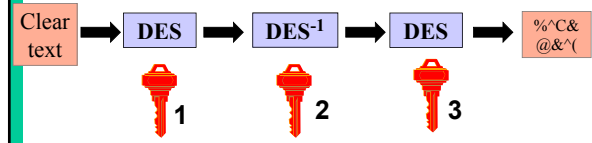

43

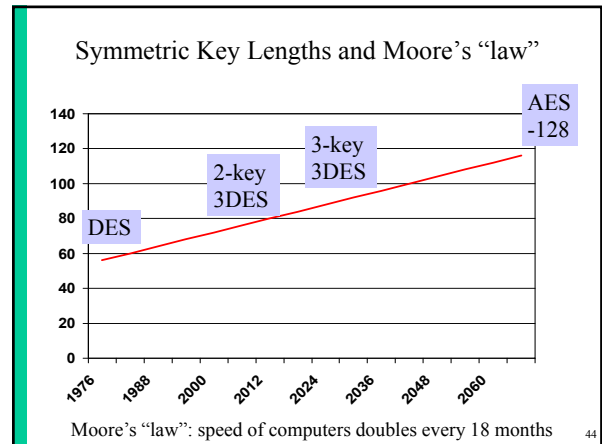

AES (Advanced Encryption Standard)

- open competition launched by US government (Sept. '97) to replace DES
- 22 contenders including IBM, RSA, Deutsche Telekom
- 128-bit block cipher with key of 128/192/256 bits
- as strong as triple-DES, but more efficient
- royalty-free

A machine that cracks a DES key in 1 second would take 149 trillion years to crack a 128-bit key

45

AES: Rijndael

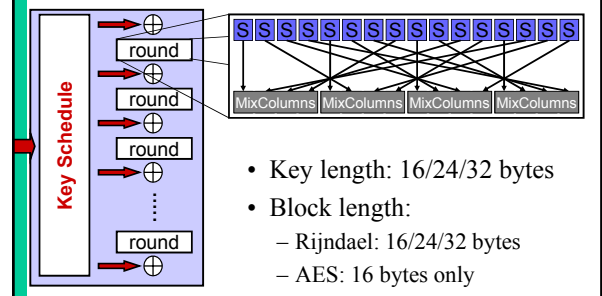

- Key length: 16/24/32 bytes
- Block length:
 - Rijndael: 16/24/32 bytes
 - AES: 16 bytes only

46

AES (2001)

- FIPS 197 published on December 2001 after 4-year open competition
 - other standards: ISO, IETF, IEEE 802.11,...
- fast adoption in the market
 - except for financial sector
 - NIST validation list: > 3200 implementations
 - <http://csrc.nist.gov/groups/STM/cavp/documents/aes/aesval.html>
- 2003: AES-128 also for **secret** information and AES-192/-256 for **top secret** information!

47

AES (2001)

- **security:**
 - algebraic attacks of [Courtois+02] not effective
 - side channel attacks: cache attacks on **unprotected** implementations
- **speed:**
 - software: 7.6 cycles/byte [Kasper-Schwabe'09]
 - hardware: Intel provides AES instruction (since 2010) at 0.63..1.5 cycles/byte for decryption – AMD one year behind

[Shamir '07] AES may well be the last block cipher

48

Encryption limitations

- Ciphertext becomes random string: “normal” crypto does not encrypt a credit card number into a (valid) credit card number
- Typically does not hide the length of the plaintext (unless randomized padding)
- Does **not** hide existence of plaintext (requires steganography)
- Does **not** hide that Alice is talking to Bob (requires traffic confidentiality, e.g. TOR)

Symmetric cryptology: data authentication

- the problem
- hash functions without a key
 - MDC: Manipulation Detection Codes
- hash functions with a secret key
 - MAC: Message Authentication Codes

50

Data authentication: the problem

- encryption provides confidentiality:
 - prevents Eve from learning information on the cleartext/plaintext
 - but does not protect against modifications (active eavesdropping)
- Bob wants to know:
 - the **source** of the information (data origin)
 - that the information has not been **modified**
 - (optionally) **timeliness** and **sequence**
- data authentication is typically more complex than data confidentiality

51

Data authentication: MAC algorithms

- Replace protection of authenticity of (long) message by protection of secrecy of (short) key
 - Add MAC to the plaintext
- CBC-MAC (CMAC)
 - HMAC
 - GMAC

This is an input to a MAC algorithm. The input is a very long string, that is reduced by the hash function to a string of fixed length. There are additional security conditions: it should be very hard for someone who does not know the secret key to compute the hash function on a new input.

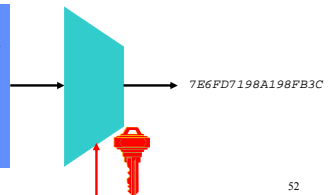

52

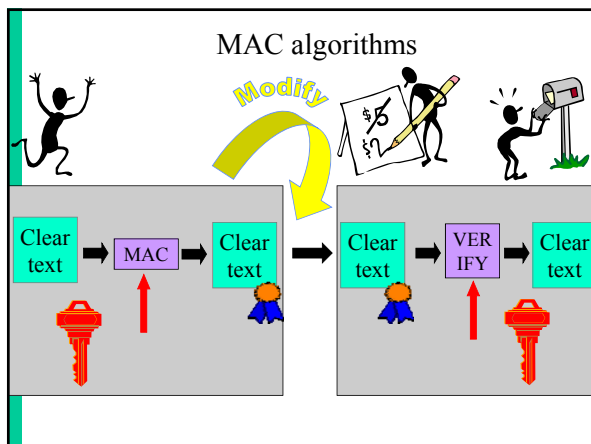

Data authentication: MAC algorithms

- typical MAC lengths: 32..96 bits
 - Forgery attacks: 2^m steps with m the MAC length in bits
- typical key lengths: (56)..112..160 bits
 - Exhaustive key search: 2^k steps with k the key length in bits
- birthday attacks: security level smaller than expected

54

MAC algorithms

- Banking: CBC-MAC based on triple-DES
- Internet: HMAC and CBC-MAC based on AES
- information theoretic secure MAC algorithms (authentication codes): GMAC/UMAC/Polynomial1305
 - highly efficient
 - rather long keys (some)
 - part of the key refreshed per message

55

CBC-MAC based on AES

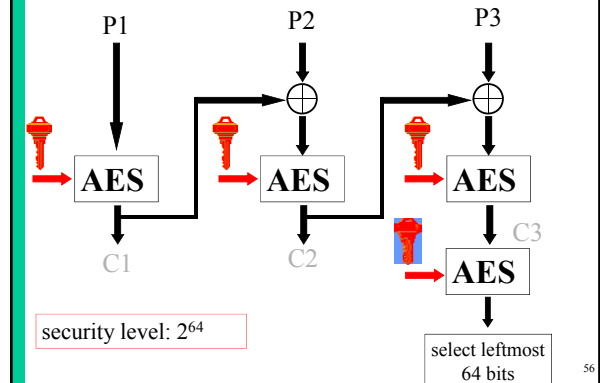

56

Data authentication: MDC

- MDC (manipulation detection code)
 - Protect short hash value rather than long text
- (MD5)
 - (SHA-1), SHA-256, SHA-512
 - RIPEMD-160
 - SHA-3 (Keccak)

This is an input to a cryptographic hash function. The input is a very long string, that is reduced by the hash function to a string of fixed length. There are additional security conditions: it should be very hard to find an input hashing to a given value (a preimage) or to find two colliding inputs (a collision).

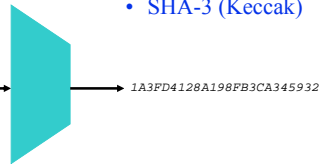

57

MDC Security requirements (n-bit result)

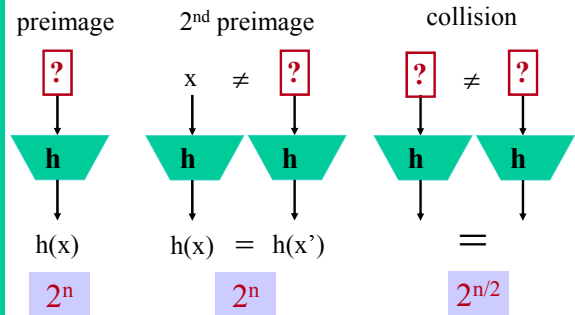

Data authentication: MDC

- n-bit result
- preimage resistance: for given y , hard to find input x such that $h(x) = y$ (2^n operations)
- 2nd preimage resistance: hard to find $x' \neq x$ such that $h(x') = h(x)$ (2^n operations)
- Collision resistance: hard to find (x, x') with $x' \neq x$ such that $h(x') = h(x)$ ($2^{n/2}$ operations)

59

Important hash algorithms

- MD5
 - (2nd) preimage 2^{128} steps (improved to 2^{123} steps)
 - collisions 2^{64} steps
 - shortcut: Aug. '04: 2^{39} steps; '09: 2^{20} steps
- SHA-1:
 - (2nd) preimage 2^{160} steps
 - collisions 2^{80} steps
 - 1.6 M\$ for 1 year in 2014
 - shortcut: Aug. '05: 2^{69} steps
- SHA-2 family (2002)
- SHA-3 family (2013) – Keccak (Belgian design)
 - (2nd) preimage $2^{256} \dots 2^{512}$ steps
 - collisions $2^{128} \dots 2^{256}$ steps

60

NIST's Modes of Operation for AES

- ECB/CBC/CFB/OFB + CTR (Dec 01)
- MAC algorithm: CMAC (May 05)
- Authenticated encryption:
 - CCM: CTR + CBC-MAC
 - GCM: Galois Counter Mode

Issues:

- associated data
- parallelizable
- on-line
- provable security

- IAPM
- XECB
- QCB

- CCM
- GCM
- (EAX)
- (CWC)

patented

61

Concrete recommendations

- AES-128 in CCM mode
 - CCM = CTR mode + CBC-MAC
 - change key after 2^{40} blocks
- Stream ciphers (better performance)
 - hardware: SNOW-3G or Trivium
 - software: HC-128 or ChaCha20
- CAESAR: open competition from 2013-2017 will come up with better solutions
 - <http://competitions.cr.yp.to/caesar.html>

62

Public-key cryptology

- the problem
- public-key encryption
- digital signatures
- an example: RSA
- advantages of public-key cryptology

63

Limitation of symmetric cryptology

- Reduce security of information to security of keys

- But: how to establish these secret keys?
 - cumbersome and expensive
 - or risky: all keys in 1 place
- Do we really need to establish secret keys?

64

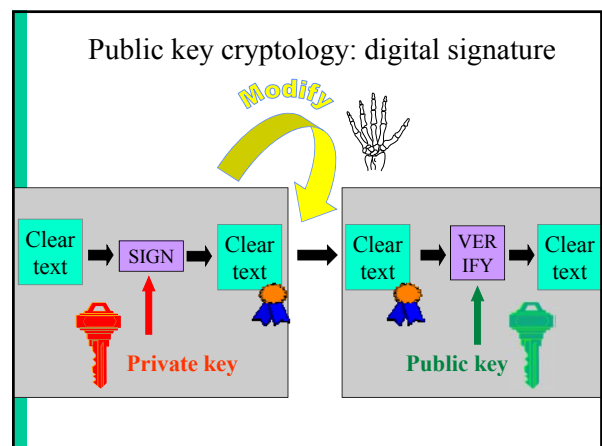
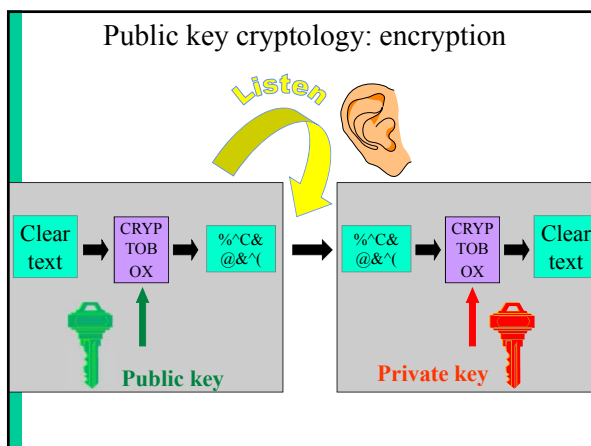

A public-key distribution protocol: Diffie-Hellman

- Before: Alice and Bob have never met and share no secrets; they know a public system parameter α

$$\begin{array}{ccc} \text{generate } x & \xrightarrow{\alpha^x} & \text{generate } y \\ \text{compute } \alpha^x & & \text{compute } \alpha^y \\ & \xleftarrow{\alpha^y} & \\ \text{compute } k=(\alpha^y)^x & & \text{compute } k=(\alpha^x)^y \end{array}$$

- After: Alice and Bob share a short term key k
 - Eve cannot compute k : in several mathematical structures it is hard to derive x from α^x (this is known as the discrete logarithm problem)

67

RSA ('78)

- choose 2 "large" prime numbers p and q
- modulus $n = p \cdot q$
- compute $\lambda(n) = \text{lcm}(p-1, q-1)$
- choose e relatively prime w.r.t. $\lambda(n)$
- compute $d = e^{-1} \pmod{\lambda(n)}$

The security of RSA is based on the "fact" that it is easy to generate two large primes, but that it is hard to factor their product

- public key = (e, n)
- private key = d of (p, q)

- encryption: $c = m^e \pmod n$
- decryption: $m = c^d \pmod n$

try to factor 2419

68

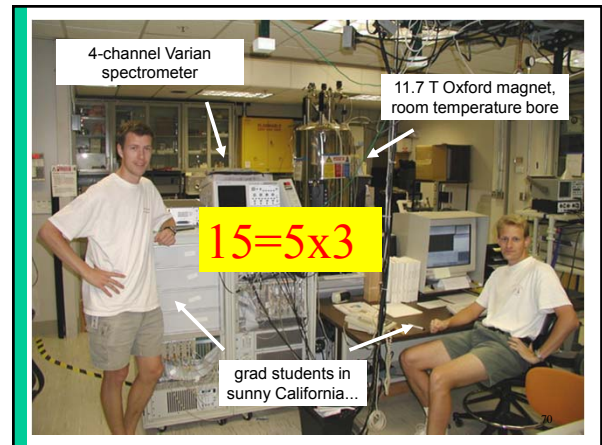
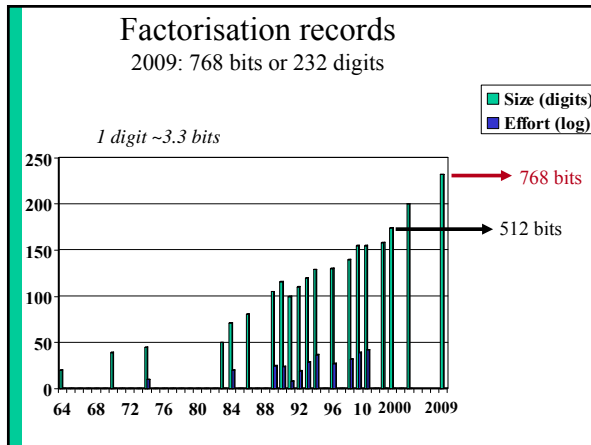

- 2001: 7-bit quantum computer factors 15
- 2007: two new 7-bit quantum computers
- 2012: 143 has been factored in Apr. '12
- 2012: 10 to 15 years for a large quantum computer

Quantum Computing: An IBM Perspective

Steffen, M.; DiVincenzo, D. P.; Chow, J. M.; Theis, T. N.; Ketchen, M. B.

Quantum physics provides an intriguing basis for achieving computational power to address certain categories of mathematical problems that are completely intractable with machine computation as we know it today. We present a brief overview of the current theoretical and experimental works in the emerging field of quantum computing. **The implementation of a functioning quantum computer poses tremendous scientific and technological challenges, but current rates of progress suggest that these challenges will be substantially addressed over the next ten years.** We provide a sketch of a quantum computing system based on superconducting circuits, which are the current focus of our research. A realistic vision emerges concerning the form of a future scalable fault-tolerant quantum computer.

71

Advantages of public key cryptography

- Reduce protection of information to protection of authenticity of public keys
- Confidentiality without establishing secret keys
 - extremely useful in an **open** environment
- Data authentication without shared secret keys: **digital signature**
 - sender and receiver have different capability
 - third party can resolve dispute between sender and receiver

72

Disadvantages of public key cryptology

- Calculations in software or hardware **two to three orders of magnitude** slower than symmetric algorithms
- Longer keys: 1024 bits rather than 56...128 bits
- What if factoring is easy?

73

Crypto software libraries

http://ece.gmu.edu/crypto_resources/web_resources/libraries.htm

C/C++/C#

- Botan (C++)
- Cryptlib (C)
- Crypto++ (C++)
- CyaSSL (C) embedded
- GnuTLS (C)
- Libcrypt (C++)
- MatrixSSL (C++) embedded
- Miracl (binaries)
- OpenSSL (C++)
- PolarSSL (C)

Java

- SunJCA/JCE
- BouncyCastle (BC, C#)
- CryptixCrypto (until '05)
- EspreSSL
- FlexiProvider
- GNU Crypto
- IAIK
- Java SSL
- RSA JSafe

Crypto recommendations

<http://www.enisa.europa.eu/activities/identity-and-trust/library/deliverables/algorithms-key-sizes-and-parameters-report>

Good

Authenticated encryption
AES-CCM
HC-128 + Poly1305
HMAC-SHA-2
SHA-3
Diffie-Hellman
 $Z_p \geq 2048$
ECC ≥ 256 and up
ECIES ≥ 256 and up
RSA KEM-DEM ≥ 2048
RSA-PSS

Bad

Encryption only, e.g. AES-CBC
RC4, A5/1, A5/2, E0, DST, Keeloq, Crypto-1,
Hitag-2, DSA, DSC, GMR-1, GMR-2, CSS
MD2, MD4, MD5, SHA-1
RSA PKCS#1v.5
DSA, ECDSA
Dual_EC_DRBG
ECC curves from NIST
SSL 3.0
TLS with RSA key exchange
Skype
Implementations that do not run in constant time

Reading material

- B. Preneel, Modern cryptology: an introduction.
 - This text corresponds more or less to the second half of these slides
 - It covers in more detail how block ciphers are used in practice, and explains how DES works.
 - It does not cover identification, key management and application to network security.

76

Selected books on cryptology

- D. Stinson, *Cryptography: Theory and Practice*, CRC Press, 3rd Ed., 2005. Solid introduction, but only for the mathematically inclined.
- A.J. Menezes, P.C. van Oorschot, S.A. Vanstone, *Handbook of Applied Cryptography*, CRC Press, 1997. The bible of modern cryptography. Thorough and complete reference work – not suited as a first text book. Freely available at <http://www.cacr.math.uwaterloo.ca/hac>
- N. Smart, *Cryptography, An Introduction: 3rd Ed.*, 2008. Solid and up to date but on the mathematical side. Freely available at http://www.cs.bris.ac.uk/~nigel/Crypto_Book/
- B. Schneier, *Applied Cryptography*, Wiley, 1996. Widely popular and very accessible – make sure you get the errata, online
- Other authors: Johannes Buchmann, Serge Vaudenay

77

Books on network security and more

- W. Stallings, *Network and Internetwork Security: Principles and Practice*, Prentice Hall, 5th Ed., 2010. Solid background on network security. Explains basic concepts of cryptography.
- W. Diffie, S. Landau, *Privacy on the line. The politics of wiretapping and encryption*, MIT Press, 2nd Ed., 2007. The best book so far on the intricate politics of the field.
- Ross Anderson, *Security Engineering*, Wiley, 2nd Ed., 2008. Insightful. A must read for every information security practitioner. Available for free at <http://www.cl.cam.ac.uk/~rja14/book.html>
- IACR (International Association for Cryptologic Research): www.iacr.org